

Digital manometer DC 400

With integrated bar graph display

Accuracy 0.5%



Description

This digital manometer is the ideal solution for local digital display independent of the mains. The integrated battery allows measurements to be made independent of a fixed source of power.

Accuracy, reliability and mechanical resilience make the digital manometer suitable pressure measurement tasks in numerous applications.

The stepped measuring ranges extend from 2 bar up to the high pressure range of 700 bar. For pressure ranges above 50 bar, the casing and parts that come into contact with the measuring medium are made of stainless steel and thus resistant to attack from chemically aggressive media.

The additional integrated bar graph display with a trailing pointer function shows the trend in current working pressure directly. The model P3962 comprises a further 4 ½-digit display for a direct readout of peak value, tare and other parameters. Internal lighting ensures the display is optimally lit for a clear readout even in unfavourable lighting conditions.

The buttons on the front are used for adjustment of the programmable parameters.

The digital manometer meets electromagnetic compatibility requirements (EMC) to EN 61326.

Features

- Measuring ranges from 2 - 700bar
- Fine step selection of nominal pressure ranges
- LC-Display with numerals 11mm high
- Bar graph display with a trailing pointer function
- Tare function
- Password protection
- MIN/MAX-memory
- Internal lighting
- High overload protection

Measuring ranges

Overpressure
positive 0...2 bar to 0...700 bar

Areas of use

Machine construction
Plant and apparatus construction
Hydraulics, pneumatics
Measuring equipment monitoring

Technical data

Series	P3961	P3962
Display – Range	7-segment LCD display, 11mm high 9999 digit Bar graph display	7/14-segment LC-Display, 11mm high 19999 digit second display 19999 digit, 7mm high Bar graph display
– Accuracy	0.5% of FS ± 1 digit ¹⁾	0.5 % of FS ± 1 digit ¹⁾
– Conversion rate	5 /sec	5 /sec
Measuring ranges to EN	0...2 bar to 0...700 bar, more on request	
Type of pressure	positive overpressure, negative overpressure	
Overload limit	2-fold, max .1000 bar	
Parts in contact with measuring medium	Measuring ranges ≤ 50 bar stainless steel; alumina; NBR, ceramic measuring cell Measuring ranges ≥ 100 bar stainless steel only, thin-film type measuring cell	
Pressure union	G 1/4 B, 1/4 NPT others on request	G 1/4 B, 1/4 NPT (300°)Rotatable
Stability per year	≤ ± 0,2 % of FS under reference conditions	
Peak value memory	MIN / MAX	
Progr. parameters – tare – autom. turn-off time – measuring unit	without without, option 2...90 min. factory set bar, PSI MPa adjustable	≤ ± 20% of FS adjustable adjustable bar, PSI MPa adjustable
Display lighting	without	with
Voltage supply – service life	2 x 1.5V round cell AA 4000 hrs (AA 2000 mAh)	
Temperature comp. range	0... 60°C	
Temperature influence – Zero point – Measuring span	≤ ± 0.15% /10 K ≤ ± 0.15% /10 K	
Degree of protection – perm. rel. humidity ²⁾	IP 65 to EN 60529/IEC 529 < 90%, non-condensing	
Emitted interference ²⁾	to EN 61326	
Interference immunity ²⁾	to EN 61326	
Temperature ranges – Storage – Measured medium – Ambient	-20 70 °C -30 85 °C (-30 ... 100°C with measuring range ≥ 100 bar) -10 60 °C	
Case	Stainless steel, option protective cap black	
Weight	Approx. 0.4 kg	

FS = full-scale reading

- ¹⁾ Meas. deviation accord. to IEC 61298-2, including non-linearity, hysteresis, zero-point and final value deviation.
²⁾ Declaration of conformity on request

Dimensions (mm)

Case

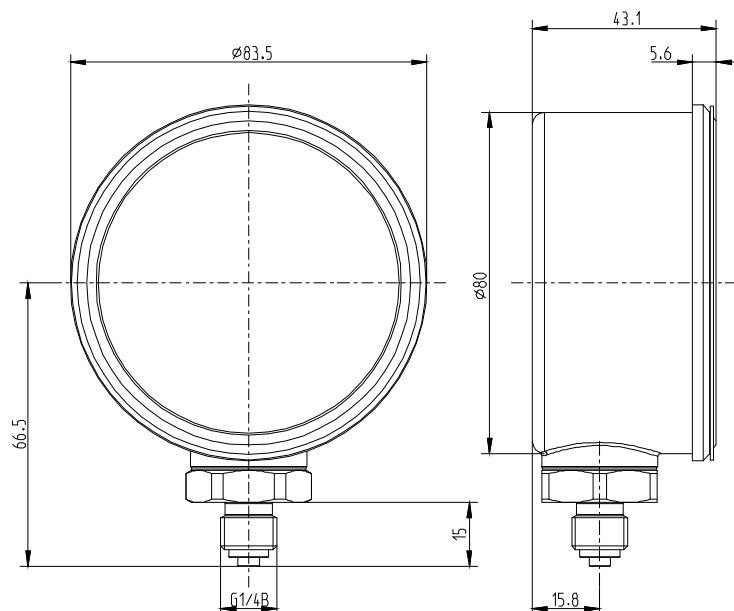

Ordering data

1. Series
2. Measuring range
3. Options